

2 - Comment coder le monde en 0 et 1 ?

1

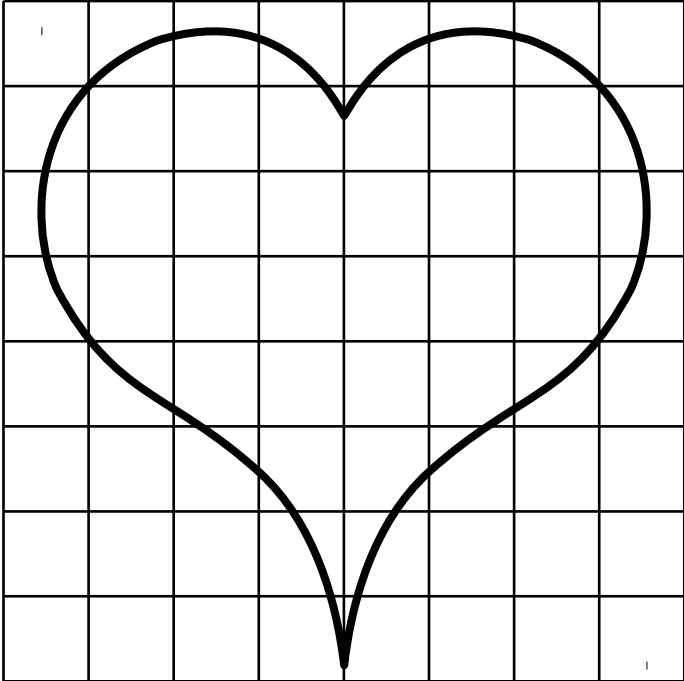

Codage de l'image :

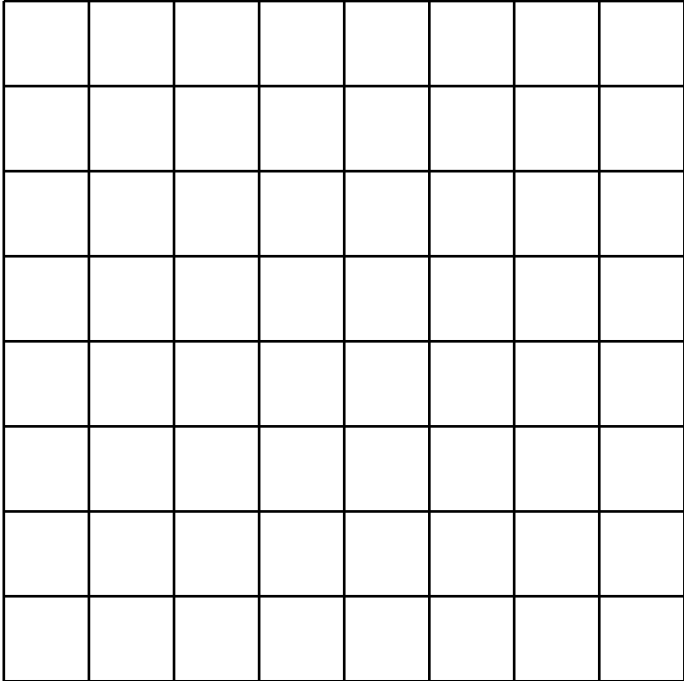

Pour cette image en noir et blanc de pixels, nous avons besoin de octets.

Ecrire le codage de l'image :

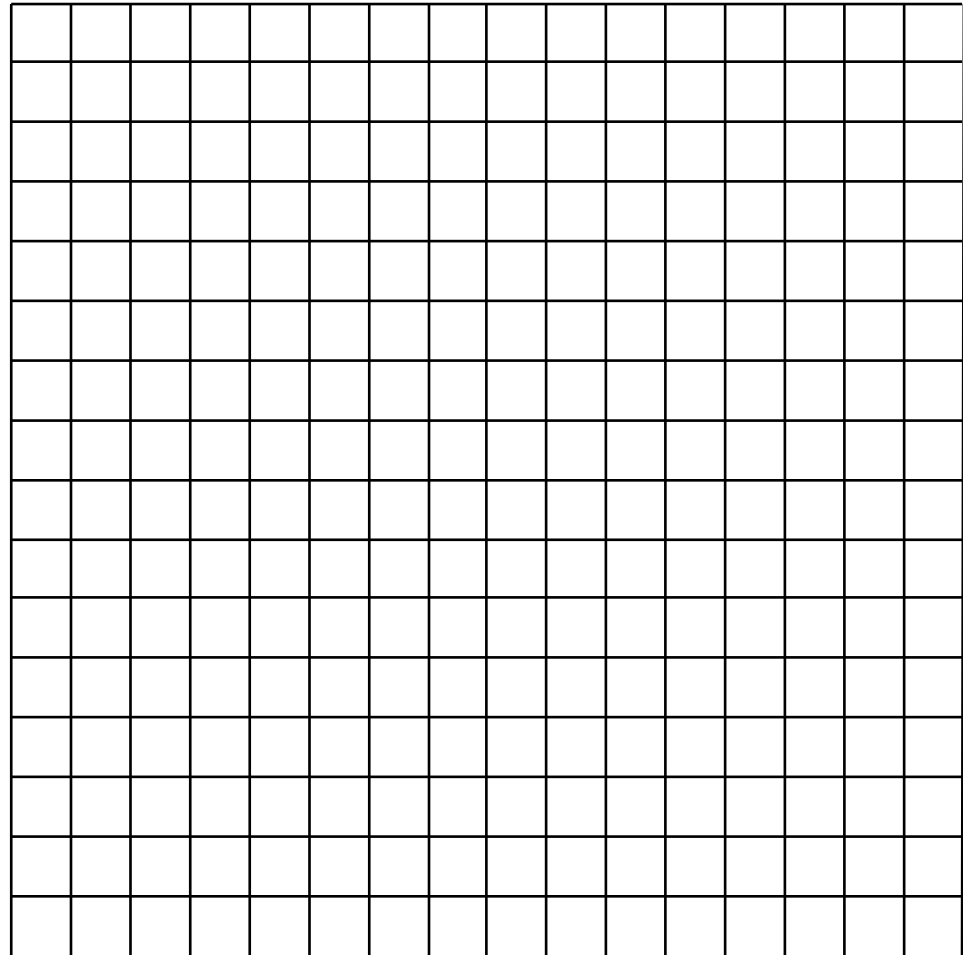

2

Codage :

1111	1011	1101	1111
1100	0001	1000	0011
1110	1011	1101	0111
1110	0011	1100	0111
1111	1111	1111	1111
1111	1110	0111	1111
1111	1110	0111	1111
1111	1100	0011	1111
0111	1101	1011	1111
1011	1111	1111	1101
1011	1110	0111	0001
1000	1010	0101	0001
1000	0000	0000	0001
1100	1010	0101	0011
1110	1110	0111	0111
1111	1111	1111	1111

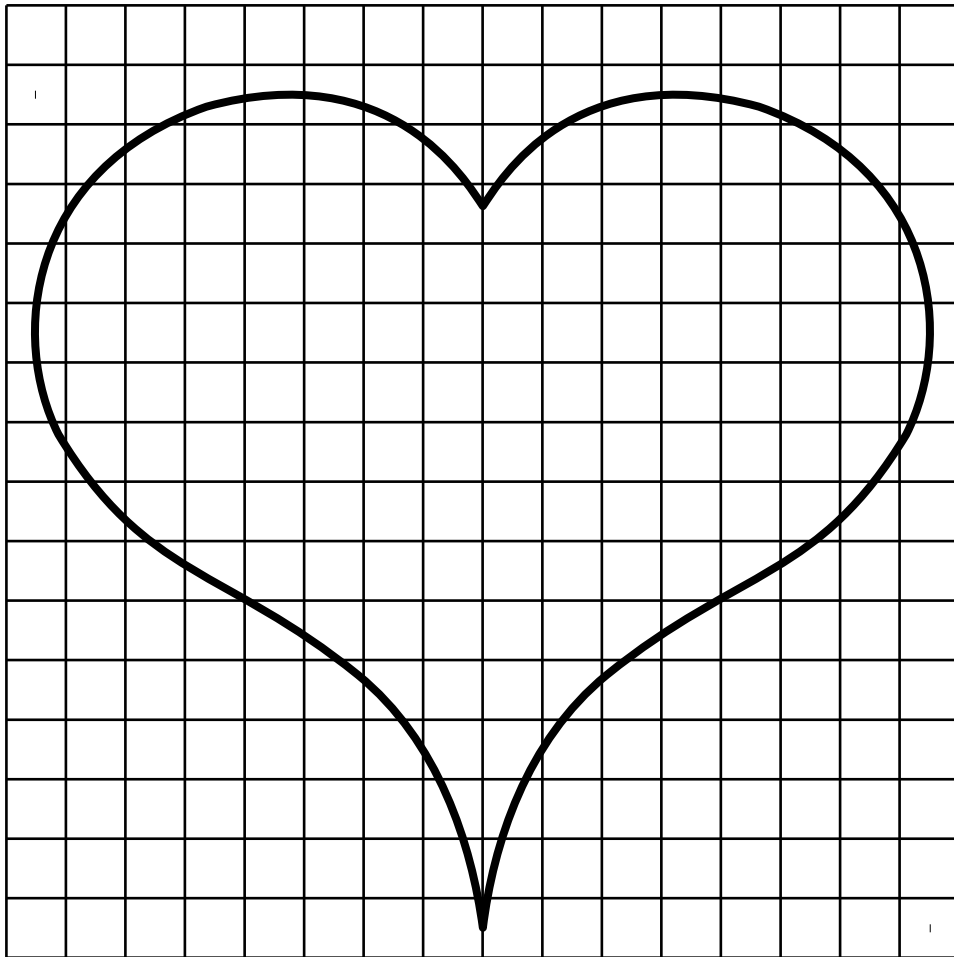

 A découper et à coller
 au dessus de la Fig.2

3

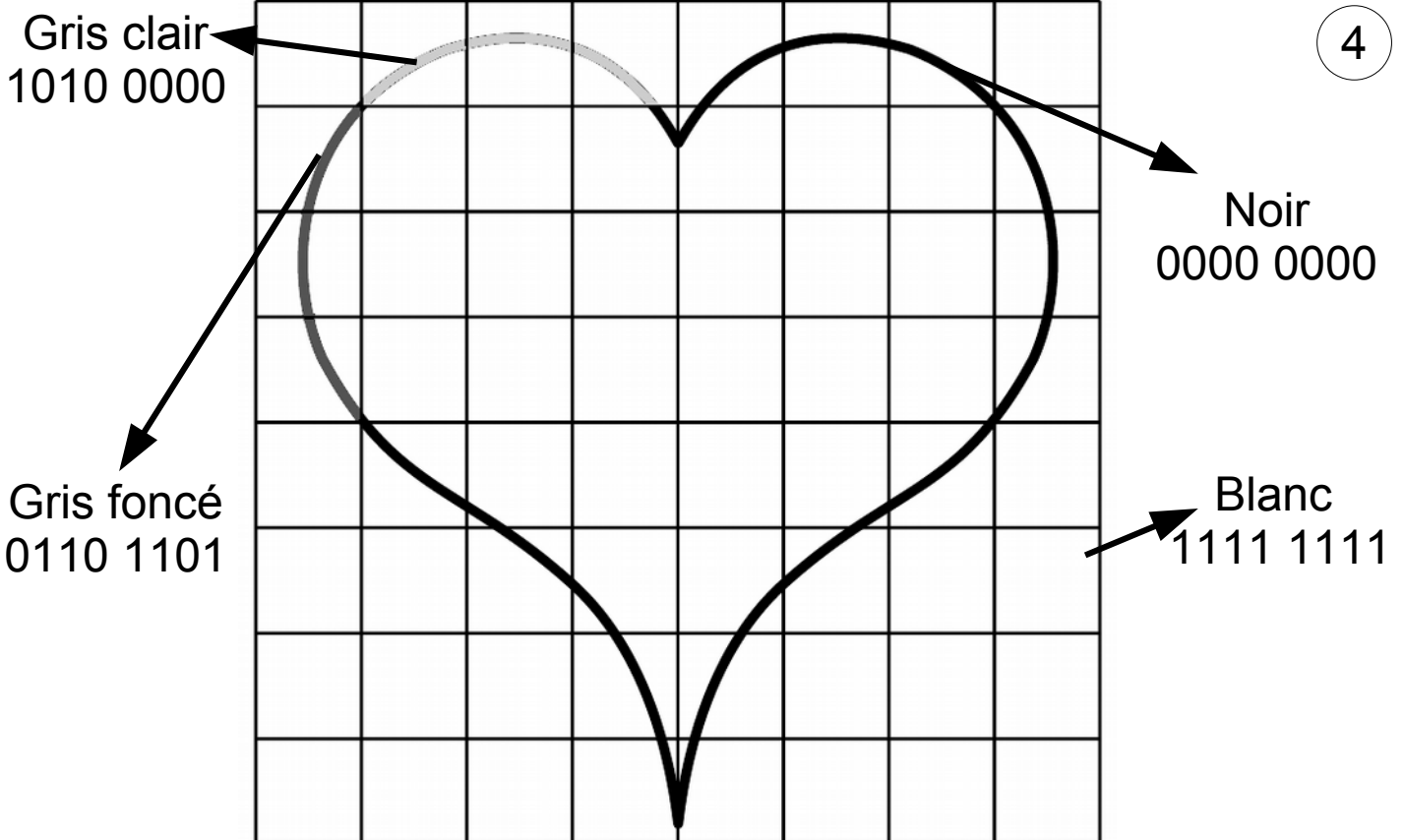

Pour cette image en noir et blanc de pixels, nous avons besoin de octets.

4



Pour cette image en niveau de gris de pixels, nous avons besoin de octets.

